

TOP NOTCH PRODUCTS

# Seamaster II



Top Notch Products Company  
PO Box 1051  
Goodlettsville, TN 37070  
[www.topnotchkits.com](http://www.topnotchkits.com)



## BEFORE YOU BEGIN

A word about laser cut parts and adhesives.

There are three primary types of adhesives recommended for constructing your model. They are Cyanoacrylate (CA) in all viscosities, Aliphatic Resin Glue (carpenters glue) and Epoxy. In the interest of speed, CA is the primary adhesive to use however there are times when it is not the best choice. They are:

1. When you need more time to carefully position a part than a fast setting adhesive will allow.
2. When attaching plastic such as a windshield (Use Pacer formula 560 here).
3. When gluing laser cut aircraft grade plywoods. The microwave set adhesives used in aircraft grade plywood does not ablate well under a laser beam. As a result it burns the wood fibers near by leaving a charred edge. Fast setting CA adhesives do not allow time for the adhesive to penetrate this layer of char and bond to the wood fiber underneath. Use a slower setting adhesive such as Aliphatic Resin or for maximum strength use Epoxy on aircraft grade ply parts. Lite Ply's do not use this type of adhesive and do not suffer from this problem.

To apply thin CA I recommend the Dave Brown pipet's available at your hobby shop. Be sure to stretch the end (pull it with a pair of pliers) to a thin applicator tip, as they are not supplied in this configuration and some folks don't know that you have to do this. No mention of this is made on the package they come in.

I recommend revisiting all CA joints with an application of Aliphatic resin glue for maximum strength.

## ASSEMBLE THE PIN REGISTRATION BLOCKS

Assembling the registration pins.

We will be using two types of pins; registration pins and push pins. **Registration pins** are assembled from two 1/4" ply parts, one 1/16" ply part and two 8d nails. **Push pins** will be used to temporarily secure parts to the building board.

Locate the two 1/4" ply parts labeled PB and one 1/8" ply part labeled PB. Refer to the graphic at the right and assemble using Epoxy or aliphatic resin glue. After installing the nail, use Epoxy to secure the nail from the bottom. Note that the assembly must sit flat on the bench when completed.

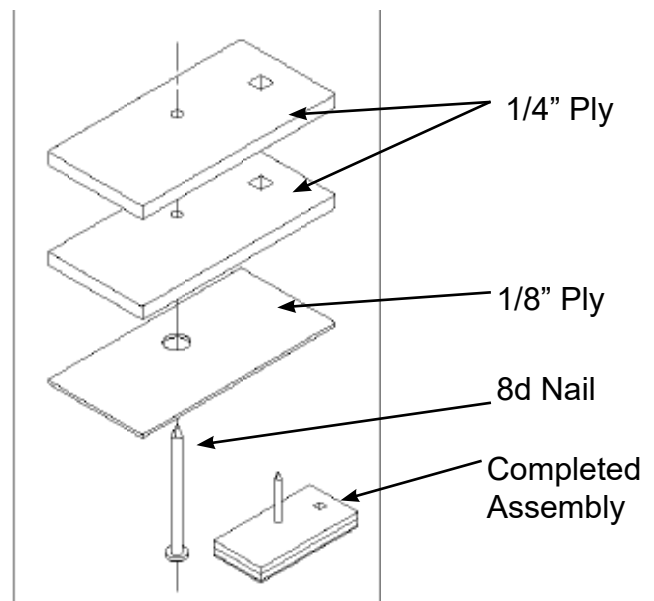

### IMPORTANT:

The magnets used in this kit are the highest quality and strength available however you must take precautions. DO NOT heat these magnets when covering your model. A temperature as low as 150° can deplete half the magnetic strength.

## Seamaster II Fuselage Assembly

- 1 Locate and prepare the two fuselage sides (FS). Lay them on the workbench with the tops facing each other (back to back, see photo).
- 2 Locate and prepare the wing saddle doublers (WS).
- 3 Use the Registration Pins to install and glue it to the fuselage sides. Note that you will make a LEFT and a RIGHT fuselage side. See the photo.
- 4 Locate the Fuselage Servo Tray (FST) and two 3/16" x 3/8" x 4" basswood rails. Note that FST can be configured for standard size servos (remove the dash cut area) or for micro servos. Determine which you will be using and configure it appropriately. Glue the basswood rails to the edge of the servo opening to provide material for the servo screws. Glue them in position.
- 5 Now is a good time to mark and drill the pilot holes for the servo mounting screws.
- 6 Install and glue the Fuselage Servo Tray assembly to F5 and F6, note that the servo tray screw rails should be on the bottom.
- 7 Glue the F5 and F6 assembly to the RIGHT fuselage side.
- 8 Locate the Wing Mounting Plate and two #10-32 blind nuts. Press the blind nuts firmly into the holes provided in WMP.
- c 9 Because WMP and F8 interlock it is best to install them at the same time. First install and glue WMP into the notches in F8 and then glue this assembly to the fuselage side. Note that the flanges of the blind nuts should be facing down.
- 10 Test fit the left fuselage side to the right fuselage side assembly. When all notches and tabs are aligned, apply glue and secure the two halves together.

Note: Make sure the fuselage assembly is flat on the building bench. Weight the assembly down until the glue cures to insure a straight fuselage.

- 11 Locate F1, note the dashed line at the bottom, and sand the bottom to taper from back to front down to the dashed line. This will conform to the curve at the bottom of the fuselage side when installing the fuselage bottom.

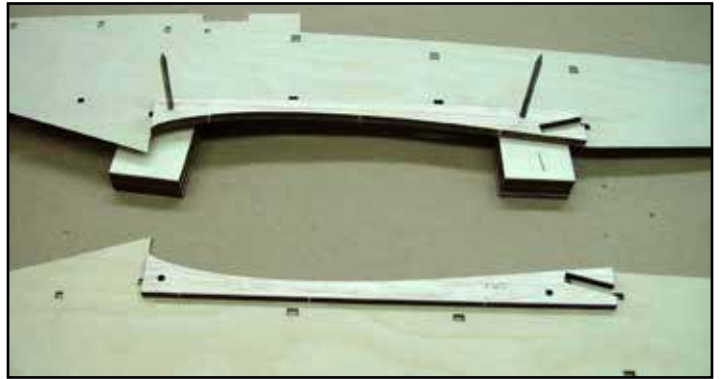

The left and right fuselage sides are laid out and the wing saddles are installed using the registration pins.

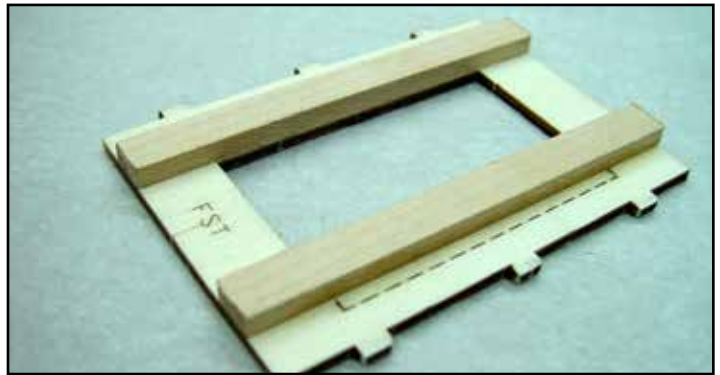

ABOVE: The servo tray can be configured to fit standard or mini servos. Remove the dash cut material for standard servos.  
BELOW: F5, F6 and the servo tray assembly.

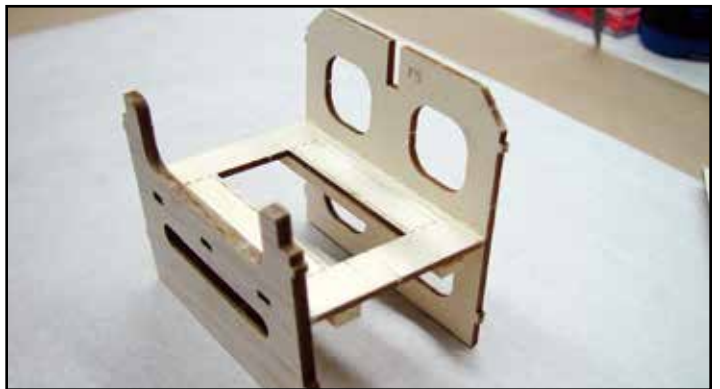

Here only half of the bottom of F1 has been beveled to the dashed line to accommodate the curved bottom sheeting. Leave the tab until after the sheeting has been attached.

- 12 Install and glue F1 to the fuselage assembly. Use some scrap wood and rubber bands to secure it until the glue cures.
- 13 Install BUT DO NOT GLUE formers F2, F3 and F4.
- 14 Locate MGM and install four #4-40 blind nuts in the holes provided. Use the registration pins to install and glue this to the inside (unlabeled side) of forward fuselage bottom (FB).
  
- 15 Test fit FB making sure the tab on F5 engages the notch provided. At the front the bottom should lay flat against F1 with the notch centered in the slot provided. When satisfied with the fit, glue Only F6 to FB taking care to insure it is straight on the fuselage and square to F5 and let it cure thoroughly.
- 16 Pull the sides in against each former F2, F3 and F4 and glue the sides to the formers.
- 17 Pull the front of FB up snug against F1 and glue it there.
- 18 Check that both fuselage sides are exactly the same and snug against the formers when satisfied with this glue the bottom of F2 to FB. Proceed on to F3 and FB and finally F4 and FB. Your fuselage sides should have equal amounts of FB extending on each side.
- 19 Glue the fuselage sides to FB.
- 20 Install and glue the Battery Tray (BT) to F1 through F4.
- 21 Cut two pieces of 1/4" triangle stock 8-1/2" long and glue one to each side of the fuselage at the top of F1 through F3 and butt up to F4.
- 22 Cut two 13-1/2" pieces of 1/4" triangle stock and glue one to each side of the fuselage between the side (FS) and the bottom (FB).
- 23 Cut a piece of 1/4" triangle stock to fit along the sides at the windshield. Taper both ends to fit and then glue in place. Note that you will need to cut and remove the 1/4" triangle stock at the notch in the fuselage side to allow next part to be installed. Use the notch in the fuselage side as your guide.
- 24 Cut a piece of 1/8" x 1/4" Basswood to fit across the fuselage and then glue it into the notches at the base of the windshield

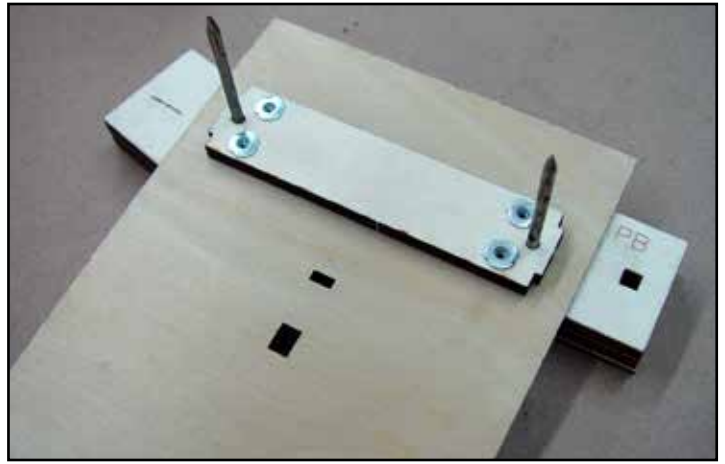

*MGM Installed on the inside of the fuselage bottom.*

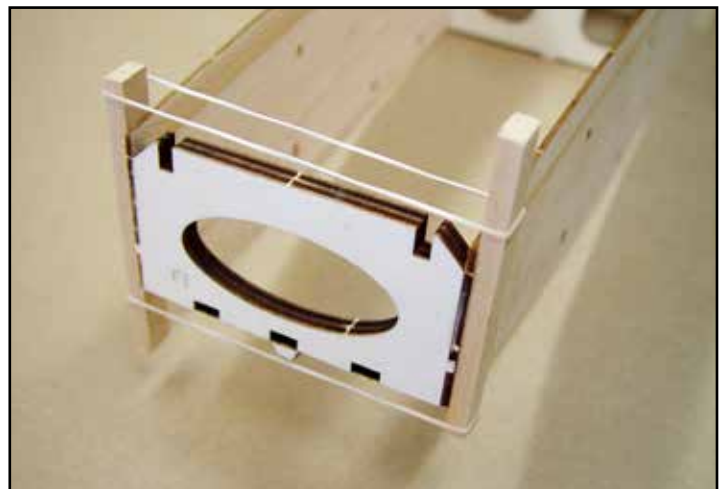

*Two pieces of scrap wood are retained with a rubber band to hold the side snugly against F1 until the glue sets.*



*Installing the fuselage bottom, a piece of scrap balsa is beveled as required to provide the clamps a flat surface to grip.*



- 25 Pull the tail section together, carefully align the fuselage sides and glue the tail section together.
- 26 Install and glue F7.
- 27 Install and glue F9 and F10 taking care to keep the fuselage perfectly straight.
- 28 Cut two pieces of 3/16" square stock to 21-1/2" long. Place them in the notches provided on each side of F7 through F10 and taper as required at the tail section. Glue these to the fuselage sides and the formers taking care to keep the fuselage straight.

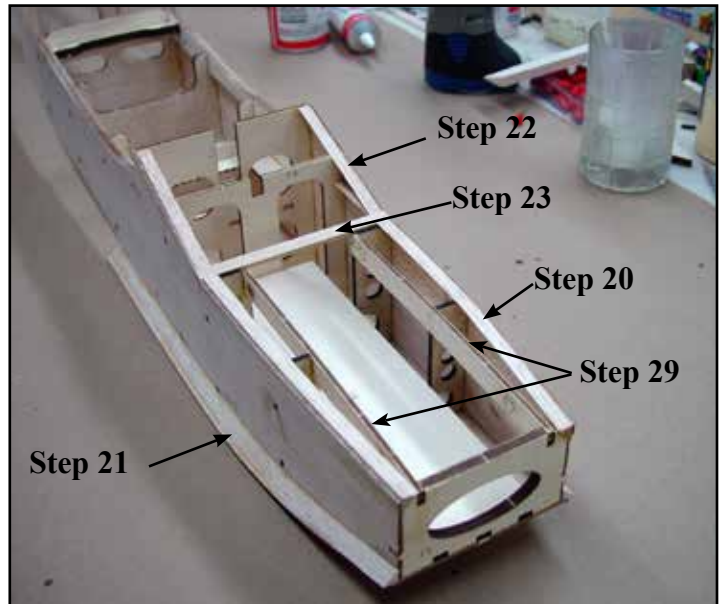

- 29 Locate two F13 pieces. Install a 1/4" x 1/8" magnet in each of the four holes supplied, use a liberal application of CA glue to retain the magnets. Install and glue one F13 on each side of the hatch area from F1 through F3. Don't worry about polarity at this time; we will take care of that later.
- 30 Cut two pieces of 3/8" triangle stock to 16" long and install and glue to the top of the aft fuselage and formers F8, F9 and F10. Taper as required at the tail section. HINT: Cut both pieces of triangle stock from the same stick, this will improve the odds that both sticks will be about the same stiffness.

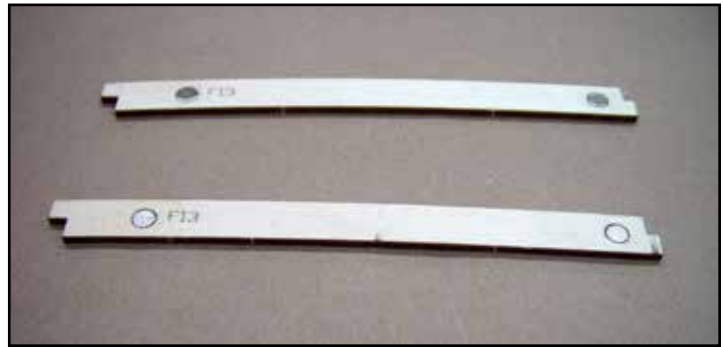

*Use thick CA to install all magnets. At this point polarity does not matter, we will match the polarity later when we install magnets in the hatch.*

- 31 Locate and prepare the bottom sheeting, FB-1 through FB-7. Assemble these to make the bottom sheet for the fuselage. This is best done over a sheet of Parchment paper to prevent sticking to the workbench. When assembled, glue the bottom sheeting to the fuselage.
- 32 Locate and assemble the top sheeting FT-1 through FT-5 in the same manner. When installing the top sheeting, insure that the slots in the top sheeting are aligned with the slots in F9 and F10 and that labeled side is up. Install and glue the top sheeting in place. Use a piece of 1/4" scrap wood to insure that the top sheeting is aligned with the slot in F10. Trim out any of the corner triangle stock in the elliptical push rod opening.



The top and bottom aft sheeting are both cut in several section that should be assembled before installing. Note the correct orientation for the top sheeting, the offset elliptical opening should be on the left side of the fuselage.

- 33 Locate and prepare the pylon parts two PL-B and one PL-A. Use the registration pins to laminate a PL-B to each side of PL-A.
- 34 Install and glue the pylon to the fuselage between F4 and F5. Insure that the tab at the bottom engages the notch in FB.
- 35 Locate two F-13 Fuselage hatch frame. Install and glue four 1/8" x 1/4" magnets into the holes provided. Medium or thick CA works best for this step.
- 36 Install and glue the F-13 hatch frames to formers F1 through F3.
- 37 Cut a piece of 1/8" x 1/4" basswood stock to 2-1/2" long and install and glue it into the notches provided at the aft end of the F13 rails.
- 38 Cut a piece of 1/8" x 1/4" basswood stock to 4-1/8" long and install and glue it into the notches provided in the fuselage sides at the bottom of the windshield area.
- 39 Install and glue the windshield (WS) to F3, F4 and F5 and the fuselage sides.
- 40 Install and glue two FST parts to the top front of the fuselage on both sides of the hatch opening. Carefully align them to be flush with F13
- 41 Located and assemble the Fuselage Nose Cone parts FNC-A, FNC-B and FNC-C.
- 42 Locate the 1-3/4" x 1-1/2" x 1/2" blocks. Place them in position in the Fuselage Nose Cone assembly and mark them for material removal. Do the same for the 3/4" x 1-1/2" x 1-3/16" blocks. Remove all excess material and then glue the blocks to the Fuselage Nose Cone assembly.
- 43 Glue the Fuselage Nose Cone assembly to F1, make the assembly flush at the bottom at F1, the top will stand proud of F1.

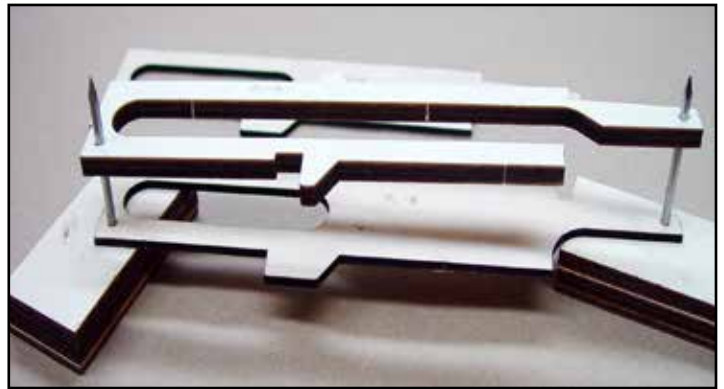

*Pylon assembly using the registration pins for accurate alignment. The pylon will support the power pod as well as provide hidden access for cabling.*

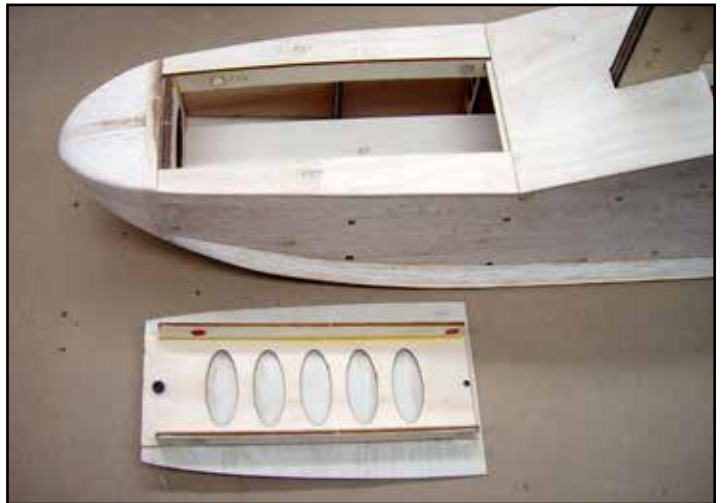

*The windshield and FST have been installed and the water resistant hatch has been assembled. This photo shows the nose cone installed however we will get to that a Little later. Follow the steps described in step 48 to get the magnet polarity correct.*

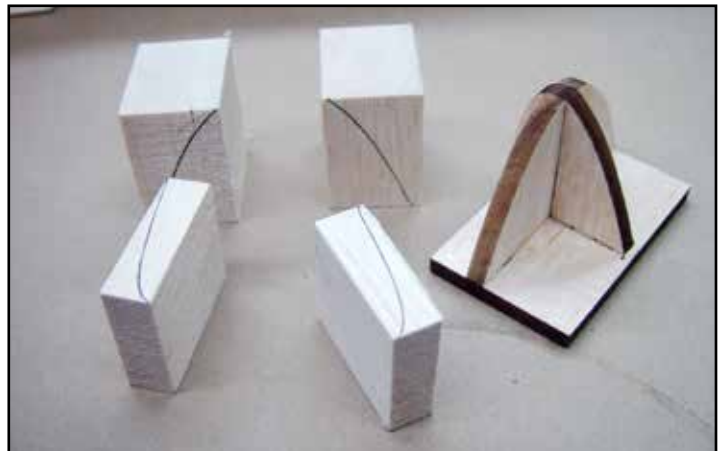

*ABOVE: The four nose cone blocks have been marked and all excess material will be cut away prior to assembling the nose block. LEFT: The nose block has been assembled and rubber bands are used to hold the assembly together until the glue sets.*



- 44 Carve and sand the nose cone to shape.
- 45 Locate and prepare hatch components HA and HAR. Glue the hatch rails (HAR) to HA. Insure that HAR are square to HA.
- 46 Using the registration pins, install and glue HA-B to the hatch assembly. Note that the arrow on HA points forward.
- 47 Locate four 3/32" x 1/4" magnets and allow one to attach itself to each of the four magnets in F13. They will naturally orient themselves for correct polarity. Now use a felt tip pen to mark the side of each magnet facing in toward the center of the fuselage. Install and glue each magnet in the appropriate hole in the hatch rails (HAR) with the marked side facing inward toward the center of the fuselage.
- 48 Locate prepare and assemble the stabilizer parts S1, S2 and S3.
- 49 Locate prepare and assemble the vertical fin parts V1, V2 and V3.
- 50 Glue the vertical fin assembly to the stabilizer assembly. Use the square to insure that the fin is at 90° to the stabilizer. Cut two pieces of 1/4" triangle stock and glue them at the interface of the vertical fin and the stabilizer.
- 51 Place the fuselage assembly on the building bench and weight it down to insure that it is setting perfectly flat on the bench.
- 52 Install and glue the vertical fin and stabilizer assembly to the fuselage. Insure that the stabilizer is perfectly parallel with the building bench top.
- 53 Install and glue V4 to the top of the stabilizer.
- 54 Cut a 24" length of the red outer tubing of Ny-Rod Push it through the hole in the top sheeting at the leading edge of the vertical fin and rout it through the right side of F8.
- 55 This tube will glue to the leading edge of the vertical fin, start at the top of V4 and use thin CA to glue it. Keep it centered on the vertical fin leading edge.
- 56 Cut two pieces of 1/4" triangle stock and install and glue it to both sides of the vertical fin at the fuselage top. Extend it forward to include the Ny-Rod tubing.



*This method of producing the nose cone makes it easy to maintain symmetry and reduces much of the carving needed.*

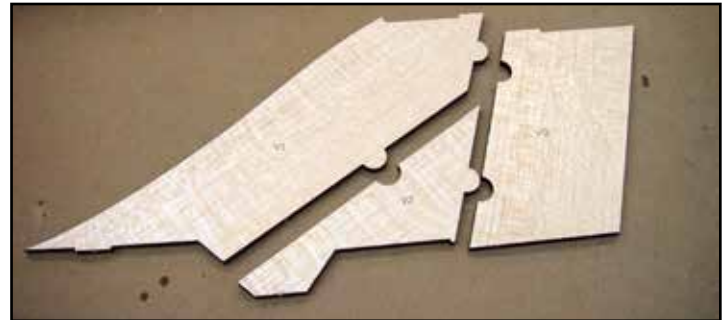

*Vertical fin sections ready to be assembled. After gluing up sand out any imperfections as it is easier to do it while you can lay it flat on the bench.*



*Use the building square to insure that the vertical fin is installed perfectly square to the stabilizer. Reinforce the joint with 1/4" triangle stock.*





Install triangle stock at the base of the vertical fin and fair it in the front to match the contour of the Ny-Rod.

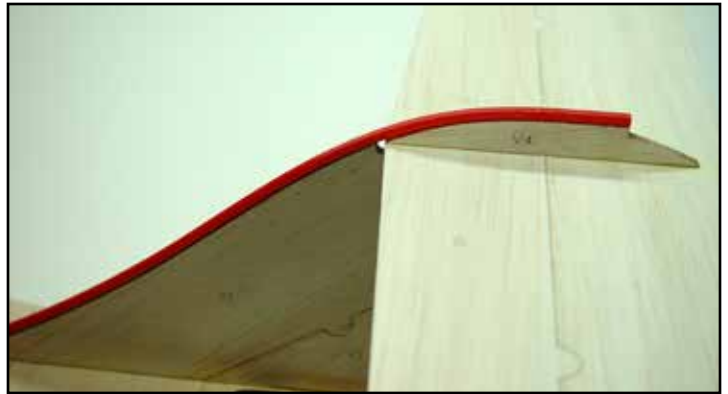

Clever use of the Ny-Rod elevator pushrod which also becomes the leading edge of the vertical fin. Use thin CA and kicker to attach this part. Fill the gap between the pushrod and the fin with wood filler.

- 57 Trim away the triangle stock from the elliptical pushrod opening on the top of the fuselage and taper it aft to accommodate the Ny-Rod when installed.
- 58 If you haven't already determined whether your going to use electric or glow power, now is the time to decide. In this case we will be building the electric version. Locate the firewall parts FW-E (E for electric and G for glow), using the registration pins, laminate the two pieces together.
- 59 Note that one side of the firewall assembly has two 1/4" holes in it at opposing corners. Install a 3/32" x 1/4" magnet in each hole. This side will be the front of the firewall, facing forward.
- 60 Locate and prepare the power pod base (PB) and the two sides (PS). NOTE: The power pod sides will be separated later. For now, keep the two sections as one. Assemble and glue the power pod base, sides and the firewall together. Note that the large notch in the firewall is on the bottom and should align with the large notch in the power pod base.
- 61 Install a 2-3/4" piece of 1/4" square balsa into the notch at the aft end of the power pod assembly. Plane or sand it to contour with the sides.
- 62 Cut a piece of 1/8" x 1-1/4" x 2-3/4" piece of basswood and glue it to the notch at the top forward of the hatch side. Take care not to glue it to the hatch side.

RIGHT: The power pod assembly underway with the firewall, sides and base held together with rubber bands in front and a clamp at the back.



After installing the triangle bracing at the bottom of the vertical fin, open up the pushrod hole, angle it aft.

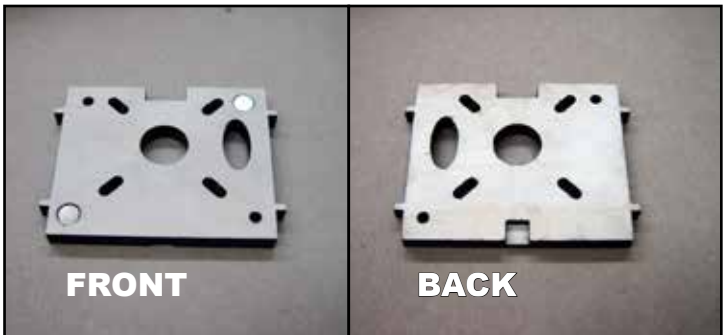

Here the electric firewall has been laminated together and the 1/4" magnets installed. The glow firewall is assembled in the same manner.

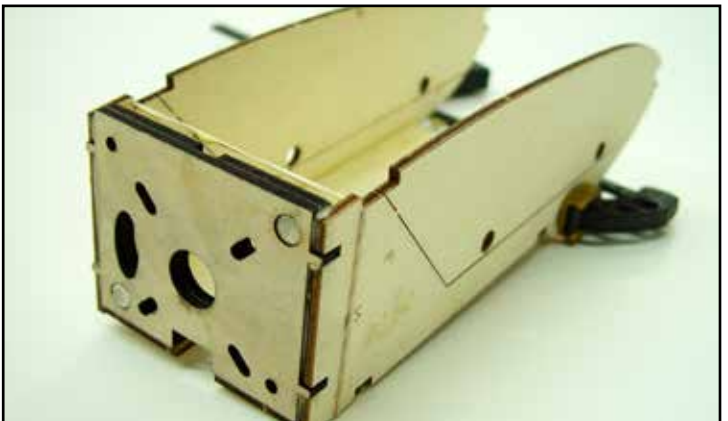

- 63 Locate and assemble the hatch top PHT-A, PHT-B and PHT-C. Glue this assembly to the top of the hatch aligned flush with the 1/8" x 1/4" piece at the front of the hatch. Do not remove the dash cut rectangle at the front of this assembly. This will be removed in a later step for the electric version. It will remain in place for the glow version. Form this assembly along the top of the hatch sides and glue it to the 1/4" square at the aft end of the hatch. After it cures, trim off the excess at the aft end.

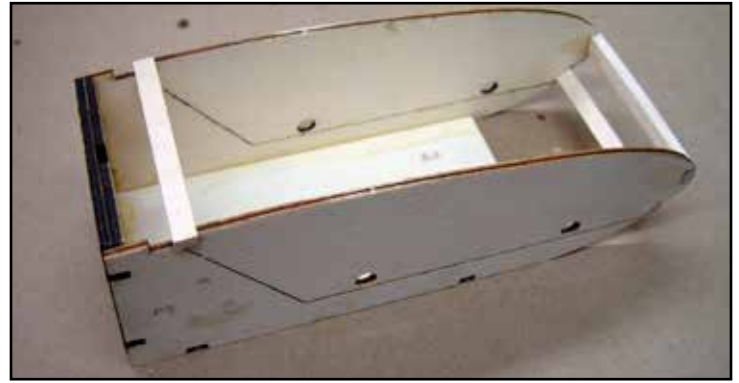

*Basswood and balsa supports are installed and then the top or removable section of the power pod is sheeted (BELOW). After that, the top can be removed from the assembly by trimming the retainer tabs.*

- 64 Plain or sand a bevel to the 1/4" square balsa at the aft end of the hatch to match the contour of the hatch sides.
- 65 Install and glue a 1/8" x 1/4" x 2-3/4" piece of basswood in the notch provided at the aft bottom of the hatch.
- 66 Glue PHB to the aft end of the hatch sides, the 1/4" square balsa and the 1/8" x 1/4" basswood. Note, for the glow version do not remove the circular openings in PHB. These are cooling air exits for the electric version.

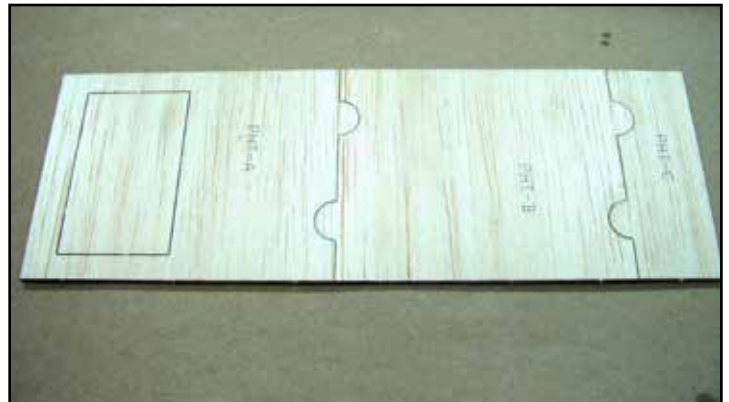

*The hatch top sheeting is assembled above, note the dash cut opening at the front of the assembly will be opened later on the electric version only.*

- 67 There are four 1/16" tabs attaching the hatch to the power pod sides, trim these tabs and remove the hatch.
- 68 Using the registration pins, install and glue a (HAC) to the inside of each side of the power pod.
- 69 Cut a 1/8" x 1/4" x 2-1/2" piece of basswood and glue it into the notch provided at the aft end of HAC.
- 70 Install and glue the pylon, insure that the tab at the bottom engages the notch on (PB). Glue it to PB, F4 and F5.
- 71 For the electric version only, open up the dash cut rectangle in the top of the hatch and install the printed air scoop.
- 72 Install and glue four 3/32" x 1/4" magnets into the holes provided in HAC. Keep these flush to the outside of HAC.



- 73 Place another 3/32" x 1/4" magnet against each of these magnets on the inside of HAC. Use a Sharpie marker to mark the inside of each of these magnets to keep the correct orientation. Then install each of these magnets into the hatch sides with the marked side inward. Be sure to put them in the matching location on the hatch. Thick CA works best for this step.

- 74 Install and glue the power pod to the pylon assembly.
- 75 Install and glue a 1/8" x 1/4" x 2-3/4" piece of basswood in the notch provided at the top of the top of the power pod just aft of the firewall. This will glue to both sides of the power pod and the top of the pylon.
- 76 Glue the power pod top (PT) to the firewall, both sides and the 1/8" x 1/4" brace.
- 77 Cut three 12" long pieces of 1/8" square basswood. Taper the leading edge and glue them to the bottom of the forward fuselage bottom using the alignment lines provided starting at the step.



*The completed power pod installed on the pylon with the water resistant hatch removed. This pod can hold a 6 oz. tank for glow power or the motor controller and battery for electric power.*

## Optional Landing Gear Assembly

- 1 Locate MPG-A and two MGP-B parts. Use the registration pins and glue the MGP-B parts to MGP-A. Glue them to the unlabeled side of MGP-A.
- 2 Use one registration pin and carefully align the second hole and install and glue MGP-S to the labeled side of the assembly of MGP-A.
- 3 Locate the 1/8" x 8-7/8" main gear axle and secure it to the MGA assembly with two polycarbonate gear straps and four #2-1/4" sheet metal screws. Install the wheels and secure them with two 1/8" wheel collars.



*Registration pins are used to install MGP-A and MGP-B with the labeled side of MPG-A down.*



*MGP-S parts are glued to the MGP-A assembly.*



*Top and bottom view of completed mains gear.*



The tail gear mount is assembled from two printed plastic part included. This assembly will replace the water rudder when land operation is desired.

- 4 Locate the two tail gear mount halves and open up the tail wheel axle hole with a 1/16" drill. Drill the hole square to the sides of the mount.



*Plastic tail gear mount halves will replace the water rudder for land operation.*

- 5 To insure the axle is straight in the final assembly, place a 1" piece of 1/16" wire through the axle holes and another one through the bolt hole at the top of the assembly. When satisfied that the axle is square to the sides, glue the assembly together with thin CA. NOTE: debur the ends of the wire for easy insertion into the axle holes. This fit must remain snug.

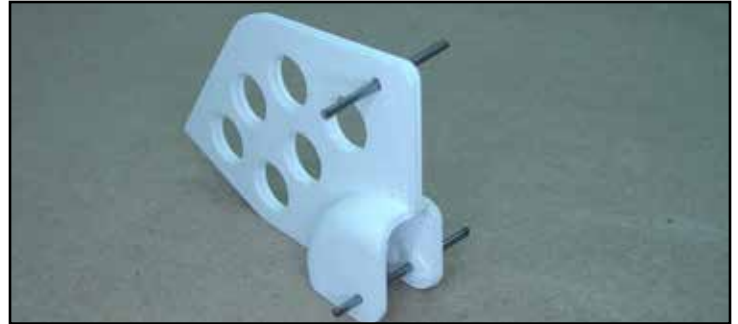

*Two pieces of 1/16" music wire are used to assist in aligning the axle before applying thin CA to the assembly. The axle shaft must be square to both sides.*

- 6 Cut a piece of the 1/16" wire to the same width as the gear mount and insert it into one side, install the wheel and then push the axle through to the opposite side. Retain the axle with a dab of thick CA on both sides of the assembly.



*The completed tail gear assembly ready for land operation.*

**NOTE:**

When installing the tail wheel assembly, remove the bolt holding the water rudder and replace the water rudder with the tail wheel assembly. Snug the retaining bolt up so the assembly will remain in the retracted position.



- 72 Locate and assemble the rudder, use the registration pins to laminate the three sections together. NOTE: The water rudder is the clear plastic part located in the parts bag. This water rudder should be attached to the rudder with a #2-56 bolt and Ny-Lock nut. It should be left loose enough to kick up in the event of contact with weeds or other objects. Also the rudder should be water proofed with a coat of thinned Epoxy resin before final assembly.



*The rudder is laminated from three sections, the ply center section has cutouts for the hinges and the kick-up water rudder is mounted to the bottom.*

Now is a good time to assemble the Hinge Slotting jig. Use it to cut the slots for the CA hinges in the trailing edge of the stabilizer and the slots for the pinned hinges in the vertical fin. Place the jig against the edge to be slotted, keep the knife parallel to the part and make several shallow passes until the desired depth is reached. The hinge locations are marked on the elevator, transfer these markings to the stabilizer and cut the slots. Place the pinned hinges into the rudder and then use this to locate the slot locations on the vertical fin.



## Wing Assembly

The wing plans may be used in one piece or cut in half if desired. Place them on the workbench and cover them with waxed paper.

- 1 Locate and prepare the false leading edge (FLE). Use a straight edge to align it with the plans. Note that the alignment line at the root end of the plans should align with the alignment line on the first standoff. Tack glue a pinning to every other stand off and secure to the bench with pins.

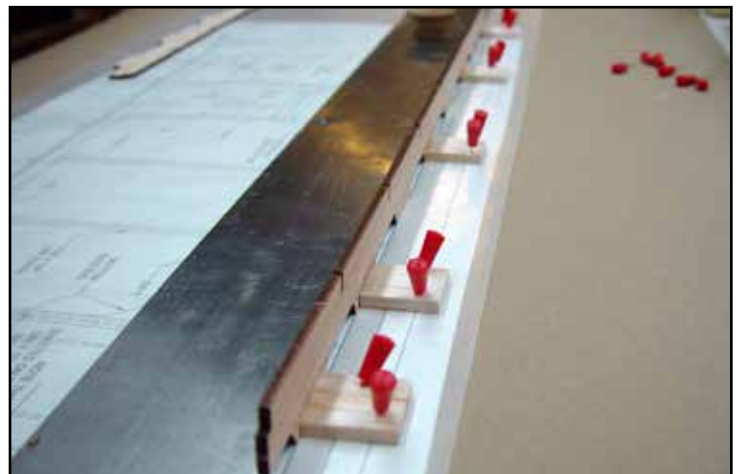

*The wing leading edge is secured to the bench by tack gluing pinning tabs to every other standoff and securing with pins. A straight edge is used to insure it is straight and it is aligned with alignment lines on the plan and the first standoff.*

- 2 Locate and prepare ribs W1 through W10.
- 3 Note that the labeling on the shear webs is on the root end. Carefully place ribs W2 through W9 into the appropriate slot in the bottom shear web.
- 4 Slide the top shear web onto the rib assembly until the top and bottom shear webs are flush to each other top and bottom. Note that this may require some patience. Remember fines not force, when everything is lined up correctly they will fall together.
- 5 While holding the assembly in your hands, press the two shear webs together top and bottom and apply a dab of CA in the glue ports. The glue ports are the elliptical holes in the shear webs for gluing. Proceed down the shear web until the full length of the shear webs has been tack glued together.
- 6 Place a 3/16" x 1/2" x 24" basswood spar in position over the plans.
- 7 Place the leading edge tab of each rib into the appropriate slot in the false leading edge and down over the basswood spar. **DO NOT GLUE** at this time.
- 8 Slide the false trailing edge into position and slide each rib into the appropriate slot. **DO NOT GLUE** at this time.
- 9 As you did on the false leading edge, line the false trailing edge up with the alignment line on the first stand off and secure it to the building board with a pinning tab at every other stand off.
- 10 Install and glue W1 to the false leading edge, the shear web assembly and the false trailing edge. Make sure W1 is in good contact with the shear webs as they will set the correct dihedral angle for W1
- 11 Now move down the wing and glue each rib to the false leading edge, the false trailing edge and the shear webs. Make sure each rib is firmly in contact with the adjoining parts before applying glue.
- 12 While holding the shear web assembly into firm contact with the bottom spar, apply glue to the entire length.

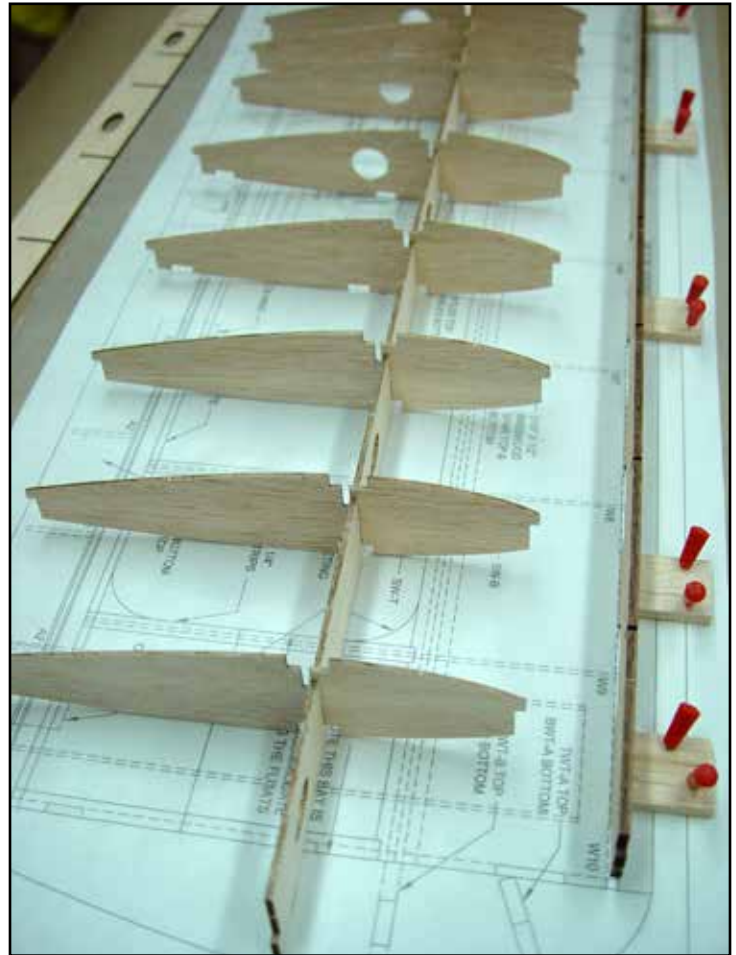

*ABOVE: All internal ribs are installed onto the bottom shear web.*

*BELOW: The top shear web has been installed and now all ribs are captive in the shear web.*

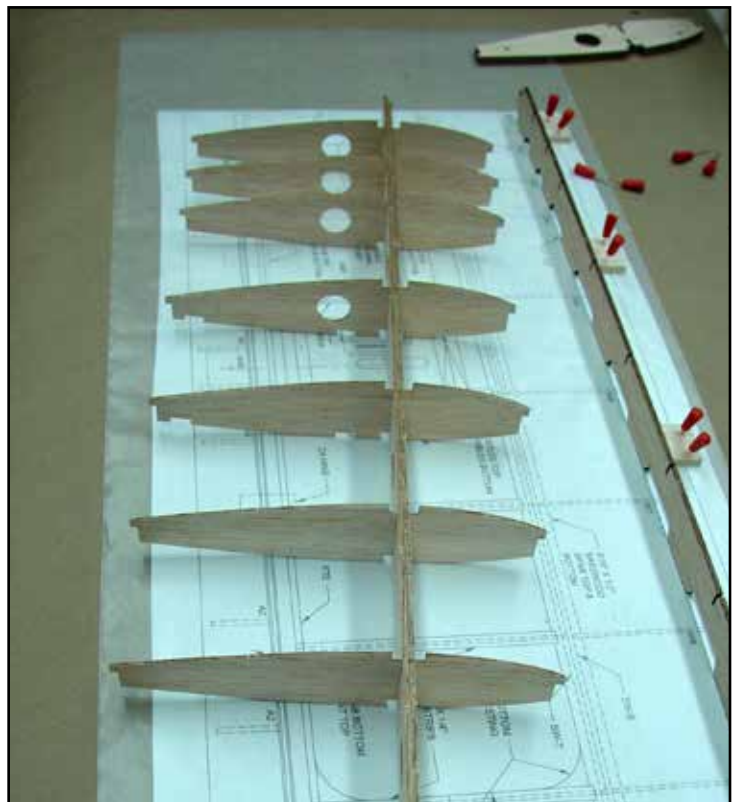

- 13 Mark and trim a 3/16" x 1/2" x 24" basswood stick to the exact length required between W1 and W10. Use aliphatic resin glue to glue the top spar to the wing assembly.
- 14 Cut a 6" length of cable tunnel tube and install and glue it to ribs W2 through W5.
- 15 Plane the false leading edge to contour with the ribs in preparation for installing the top leading edge sheeting.
- 16 Locate and prepare the top leading edge sheeting (WTLES).
- 17 To install the top sheeting it is best to use two types of adhesives, medium CA and aliphatic resin. The medium CA will quickly attach the sheeting to the top spar while the aliphatic resin will allow time to work with the sheeting to form it to the ribs. Apply aliphatic resin to the false leading edge and all the ribs between the spar and the leading edge. Apply thick CA to the length of the top spar. Place the top leading edge sheeting in place, center the cap rib openings on the ribs and then press the sheeting into contact with the spar until the CA has cured. Now use weight, tape or pins to bring the top sheeting into contact with the ribs and the false leading edge until the glue has cured.
- 18 Locate and prepare the top center section sheeting (TC-A and TC-B). Glue the two together. Then glue the assembly to ribs W1 through W4 between the spar and the trailing edge. Note that the trailing edge is slightly larger to fit the width of the false trailing edge.

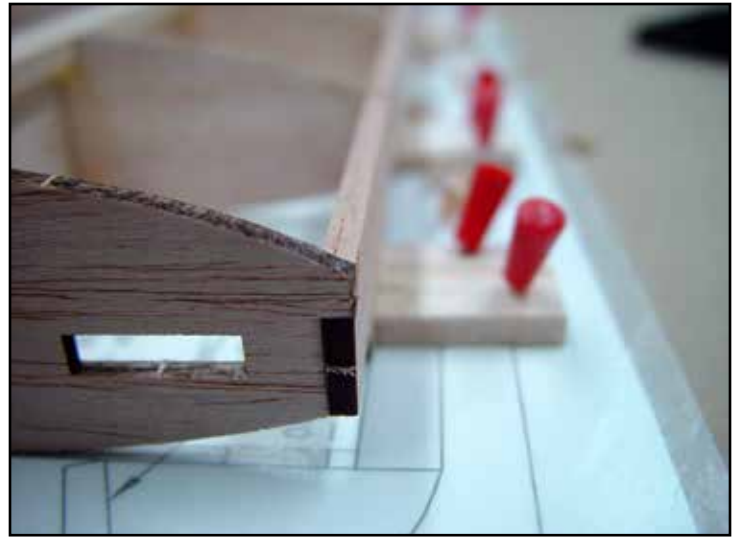

*The false leading edges is beveled to contour with the wing ribs in preparation for installing the top leading edge sheeting.*

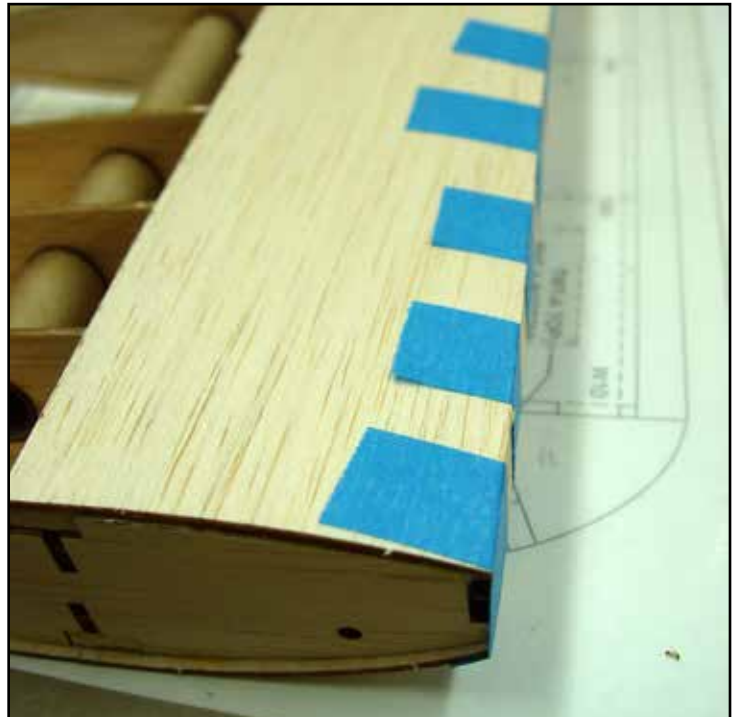

*The top and bottom sheeting are installed in the same way, using medium CA along the spar for a quick cure and aliphatic resin on all remaining ribs and false leading edge to allow time to work. Tape is used to secure the sheeting until the aliphatic resin glue sets.*



- 19 Locate, prepare, install and glue all the top cap strips, they are located on sheet #14 and the top cap strips are labeled with a T.
- 20 Remove the wing assembly from the plan and turn it over. Snap off all the standoffs on the false leading edge and the false trailing edge. Save the pinning tabs for the remaining wing half.
- 21 Taper the false leading edge to contour with the ribs.
- 22 Locate, prepare and install the bottom leading edge sheeting in the same manner as you did the top sheeting. Use strips of masking tape to secure the leading edge.
- 23 Locate and assemble the bottom center section sheeting (BC-A and BC-B)
- 24 Install and glue the bottom center section sheeting.
- 25 Install and glue the ply-reinforcing ring around the servo lead hole.
- 26 Install and glue the servo mounting rails (SMR). The side with the screw holes should be facing each other.
- 27 Assemble the bottom wing tip sheeting (WTS-A and WTS-B). Install and glue it to ribs W9 and W10.
- 28 Install and glue bottom cap strips to ribs W5 through W8, note that the cap strips on rib W5 and W6 has a cut out in them for the servo mounting plate, refer to the plans for correct orientation. Note that the longer end goes toward the leading edge.
- 29 To finish framing out the servo mount opening, install and glue the two (SO) pieces at the front and back of the opening. These should butt up against the cap strips on W5 and W6.
- 30 Install and glue the trailing edge (TE) to the false trailing edge. Use several pieces of 1/8" dowel in the holes provided to insure accurate alignment. These alignment dowels can be left in permanently if desired.



*Here the bottom leading edge and center section sheeting have been installed and tape is used to secure the sheeting until the aliphatic resin has set.*



*W5-A and W6-A are installed as shown above, they will provide a ledge that the servo mount will rest on.*



*The ply servo mounts are installed between W5 and W6.*



- 31 Cut, install and glue the leading edge from a piece of 3/8" x 3/4" x 36" balsa stick. Use pins and tape to secure it until cured.
- 32 Sand the wing tip flat if there are any protrusions. Install and glue the wing tip (WT). Use the gussets TWT-A and TWT-B on the top and gussets TWB-A and TWB-B on the bottom.
- 33 Install and glue the four 1/2" x 2-3/4" triangle pieces to the trailing edge of the wing tip, top and bottom.
- 34 Locate and assemble the float parts Two TFS, one TFK-A and one TFK-B. Glue TFK-A and TFK-B to one of the float sides TFS.
- 35 Glue the remaining float side to the float assembly.
- 36 Locate and prepare the float sheeting, parts A,B,C and D. Assemble and glue parts A,B and C.
- 37 Install and glue the aft sheeting section D.
- 38 Install and glue the forward sheeting assembly, note that you may have to wet the sheeting to make the bend without breaking. Use Windex or water with ammonia in it to wet the wood. The tip floats will be installed into the slots provided in the wing sheeting however you may want to cover the wing and the floats before attaching them to the wing

This completes this half of the wing construction, return to step one of the wing construction and repeat the assembly instructions for the remaining wing section.



*Dowels are used to precisely position the trailing edge and clamps secure it until the glue sets.*

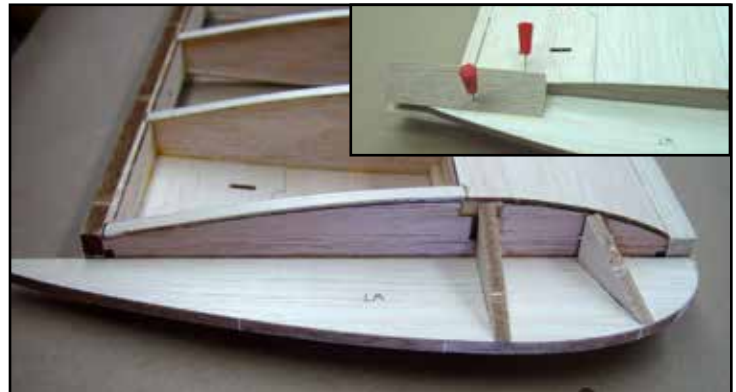

*The wing tip and the wing tip gussets are installed. The inset shows the triangle stock installed the trailing edge to strengthen the wing tip.*



*Use the leading edge template to help in shaping the leading edge.*



*ABOVE: Pontoon construction begins with the assembly of TFK-A and TFK-B, then the sides are installed. RIGHT: The pontoon assembly ready for sheeting. Tabs will position it on the bottom wing sheeting.*



## Assembling the wing halves

- 1 Locate, prepare and laminate the wing hook parts (WH) using the registration pins.
- 2 Cut two 1/8" x 1" dowels and place them in the alignment holes. Glue them to the WH assembly protruding equal amounts on both sides.
- 3 Test fit the WH assembly to both wing halves. When satisfied with the fit, glue the WH assembly to one wing half and then glue the remaining wing half to WH.
- 4 Laminate the two TEX parts together; note that the labeling should be on the outside of the parts. Bevel the leading edge slightly to fit. Place the wing onto the fuselage and center it. Glue the TEX assembly to the trailing edge taking care to keep it centered.
- 5 Use a mixture of Z-Poxy thinned with denatured alcohol to apply the 3" wide fiberglass cloth. Lay the cloth in position and then brush on the finishing resin mixture. Don't be alarmed if the cloth appears to have a dry look, most of the resin will soak into the wood but it will adhere the glass cloth to the wing.



*The wing hook assembly with dowels installed, ready to join the wing halves.*



*The servo mounting plate should fit snugly to help waterproof the servo and wing assembly.*



*Aileron servo showing the servo mount installation. Use plenty of CA on the ply mounts.*



*Laminate the two trailing edge extensions (TEX) using the pin registration system, keep the labeled sides out.*

## Aileron assembly

- 1 Locate and prepare the aileron base (AB). Place it on the bench with the labeled side up. This will insure a left and a RIGHT aileron. Work over waxed or parchment paper and install and glue the leading edge (ALE). Insure that it is aligned with the leading edge of AB and glue it.
- 2 Install and glue the tip ribs (A1).
- 3 Install and glue all remaining ribs (A2).
- 4 Install and glue the aileron horn block (AHB). Note that the notch in AHB should line up with the slot on AB.
- 5 Taper the leading edge and the aileron horn block to contour with the ribs, do not taper the tabs yet.
- 6 Install and glue the top sheeting (AT).

The aileron horn should be installed after covering the ailerons. After the ailerons are installed and the linkage has been installed and adjusted, install and glue the splash guards over the servo openings in the wings.

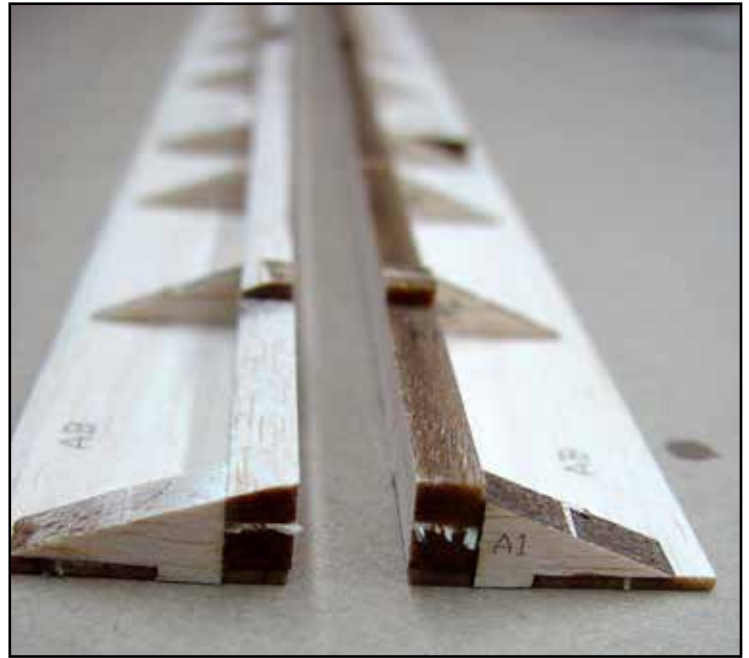

*Aileron assembly underway, on the right is the rough assembly, on the left the leading and trailing edges have been tapered to contour with the ribs in preparation for installing the top sheeting. The aileron horns should be installed after covering the ailerons.*

## Seamaster II Parts Locator

Part#	Qty.	Sheet#	Material	Size
A	2	22	BALSA	3/32 X 4 X 36
A1	4	2	BALSA	1/4 X 4 X 36
A2	1	23	BALSA	3/32 X 3 X 36
AB	2	9	BALSA	1/16 X 4 X 36
AHB	2	2	BALSA	1/4 X 4 X 36
ALE	2	2	BALSA	1/4 X 4 X 36
AT	2	14	BALSA	1/16 X 4 X 36
B	8	14	BALSA	1/16 X 4 X 36
B	2	22	BALSA	3/32 X 4 X 36
BC-A	1	17	BALSA	1/16 X 4 X 36
BC-A	1	16	BALSA	1/16 X 4 X 36
BC-B	1	18	BALSA	1/16 X 4 X 36
BC-B	1	15	BALSA	1/16 X 4 X 36
BT	1	3	LPLY	1/8 X 4 X 36
BWT-A	2	21	BALSA	3/16 X 4 X 36
BWT-B	2	21	BALSA	3/16 X 4 X 36
C	2	22	BALSA	3/32 X 4 X 36
CR	1	6	LPLY	1/4 X 4 X 18
D	2	22	BALSA	3/32 X 4 X 36
EV	1	21	BALSA	3/16 X 4 X 36
F1	1	6	LPLY	1/4 X 4 X 18
F10	1	20	BALSA	3/16 X 3 X 36
F13	2	3	LPLY	1/8 X 4 X 36
F2	1	7	ACPLY	1/8 X 6 X 28
F3	1	7	ACPLY	1/8 X 6 X 28
F4	1	3	LPLY	1/8 X 4 X 36
F5	1	3	LPLY	1/8 X 4 X 36
F6	1	21	BALSA	3/16 X 4 X 36
F7	1	20	BALSA	3/16 X 3 X 36
F8	1	21	BALSA	3/16 X 4 X 36
F9	1	20	BALSA	3/16 X 3 X 36
FB	1	8	ACPLY	1/16 X 5 X 30
FB-1	1	16	BALSA	1/16 X 4 X 36
FB-2	1	16	BALSA	1/16 X 4 X 36
FB-3	1	16	BALSA	1/16 X 4 X 36
FB-4	1	16	BALSA	1/16 X 4 X 36



## Seamaster II Parts Locator

Part#	Qty.	Sheet#	Material	Size
FB-5	1	16	BALSA	1/16 X 4 X 36
FB-6	1	16	BALSA	1/16 X 4 X 36
FB-7	1	16	BALSA	1/16 X 4 X 36
FLE	2	5	BALSA	1/8 X 4 X 36
FNC-A	1	2	BALSA	1/4 X 4 X 36
FNC-B	1	2	BALSA	1/4 X 4 X 36
FNC-C	1	2	BALSA	1/4 X 4 X 36
FS	1	26	AC PLY	1/32 X 5 X 36
FS	1	17	AC PLY	1/32 X 5 X 36
FST	1	3	LPLY	1/8 X 4 X 36
FST	2	8	ACPLY	1/16 X 5 X 30
FT-1	1	16	BALSA	1/16 X 4 X 36
FT-2	1	16	BALSA	1/16 X 4 X 36
FT-3	1	16	BALSA	1/16 X 4 X 36
FT-4	1	16	BALSA	1/16 X 4 X 36
FT-5	1	16	BALSA	1/16 X 4 X 36
FTE	2	4	BALSA	1/8 X 4 X 36
FW-E	2	7	ACPLY	1/8 X 6 X 28
FW-G	2	7	ACPLY	1/8 X 6 X 28
HA	1	8	ACPLY	1/16 X 5 X 30
HAC	2	3	LPLY	1/8 X 4 X 36
HAR	2	3	LPLY	1/8 X 4 X 36
HB	1	23	BALSA	3/32 X 3 X 36
HING SLOTTER	1	8	ACPLY	1/16 X 5 X 30
HINGE SLOTER	1	6	LPLY	1/4 X 4 X 18
LE TEMPLATE	1	3	LPLY	1/8 X 4 X 36
MGM	1	6	LPLY	1/4 X 4 X 18
MGP-A	1	7	ACPLY	1/8 X 6 X 28
MGP-B	2	7	ACPLY	1/8 X 6 X 28
MGS	2	7	ACPLY	1/8 X 6 X 28
PB	1	3	LPLY	1/8 X 4 X 36
PB	1	23	BALSA	3/32 X 3 X 36
PHT-A	1	22	BALSA	3/32 X 4 X 36
PHT-B	1	22	BALSA	3/32 X 4 X 36
PIN	4	6	LPLY	1/4 X 4 X 18
PIN	2	3	LPLY	1/8 X 4 X 36

## Seamaster II Parts Locator

Part#	Qty.	Sheet#	Material	Size
PLA	1	6	LPLY	1/4 X 4 X 18
PL-B	2	7	ACPLY	1/8 X 6 X 28
PS	2	3	LPLY	1/8 X 4 X 36
RSM	1	6	LPLY	1/4 X 4 X 18
RU	1	20	BALSA	3/16 X 3 X 36
RU-B	1	22	BALSA	3/32 X 4 X 36
RU-C	1	22	BALSA	3/32 X 4 X 36
S1	1	19	BALSA	3/16 X 3 X 36
S2	1	19	BALSA	3/16 X 3 X 36
S3	1	21	BALSA	3/16 X 4 X 36
SM	2	8	ACPLY	1/16 X 5 X 30
SMR	4	7	ACPLY	1/8 X 6 X 28
SO	4	14	BALSA	1/16 X 4 X 36
SWB	2	24	BALSA	3/32 X 3 X 36
SW-T	2	23	BALSA	3/32 X 3 X 36
T	12	14	BALSA	1/16 X 4 X 36
TC-A	1	18	BALSA	1/16 X 4 X 36
TC-A	1	15	BALSA	1/16 X 4 X 36
TC-B	1	17	BALSA	1/16 X 4 X 36
TC-B	1	16	BALSA	1/16 X 4 X 36
TE	2	2	BALSA	1/4 X 4 X 36
TEX	1	1	BALSA	1/4 X 4 X 12
TFK-A	2	22	BALSA	3/32 X 4 X 36
TFK-B	2	22	BALSA	3/32 X 4 X 36
TFS	4	25	BALSA	3/32 X 3 X 36
TWT-A	2	21	BALSA	3/16 X 4 X 36
TWT-B	2	21	BALSA	3/16 X 4 X 36
V1	1	20	BALSA	3/16 X 3 X 36
V2	1	20	BALSA	3/16 X 3 X 36
V3	1	20	BALSA	3/16 X 3 X 36
V4	1	21	BALSA	3/16 X 4 X 36
W1	2	2	BALSA	1/4 X 4 X 36
W10	2	5	BALSA	1/8 X 4 X 36
W2	1	10	BALSA	1/16 X 3 X 36
W2	1	11	BALSA	1/16 X 3 X 36
W3	1	10	BALSA	1/16 X 3 X 36

## Seamaster II Parts Locator

Part#	Qty.	Sheet#	Material	Size
W4	1	10	BALSA	1/16 X 3 X 36
W4	1	11	BALSA	1/16 X 3 X 36
W5	1	10	BALSA	1/16 X 3 X 36
W5	1	11	BALSA	1/16 X 3 X 36
W5-A	2	24	BALSA	3/32 X 3 X 36
W6	1	10	BALSA	1/16 X 3 X 36
W6	1	11	BALSA	1/16 X 3 X 36
W6-A	2	24	BALSA	3/32 X 3 X 36
W7	1	10	BALSA	1/16 X 3 X 36
W7	1	11	BALSA	1/16 X 3 X 36
W8	1	10	BALSA	1/16 X 3 X 36
W8	1	11	BALSA	1/16 X 3 X 36
W9	1	10	BALSA	1/16 X 3 X 36
W9	1	11	BALSA	1/16 X 3 X 36
WBLES	1	18	BALSA	1/16 X 4 X 36
WBLES	1	15	BALSA	1/16 X 4 X 36
WH	2	7	ACPLY	1/8 X 6 X 28
WMP	1	6	LPLY	1/4 X 4 X 18
WS	1	8	ACPLY	1/16 X 5 X 30
WS	2	21	BALSA	3/16 X 4 X 36
WT	2	21	BALSA	3/16 X 4 X 36
WTLES	1	17	BALSA	1/16 X 4 X 36
WTLES	1	16	BALSA	1/16 X 4 X 36
WTS-A	2	9	BALSA	1/16 X 4 X 36
WTS-B	2	9	BALSA	1/16 X 4 X 36

Top Notch Products Company  
PO Box 1051  
Goodlettsville, TN 37070  
**[www.topnotchkits.com](http://www.topnotchkits.com)**